

# CORE DRILLS

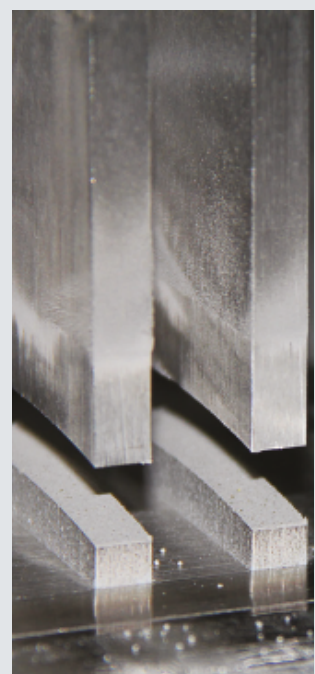

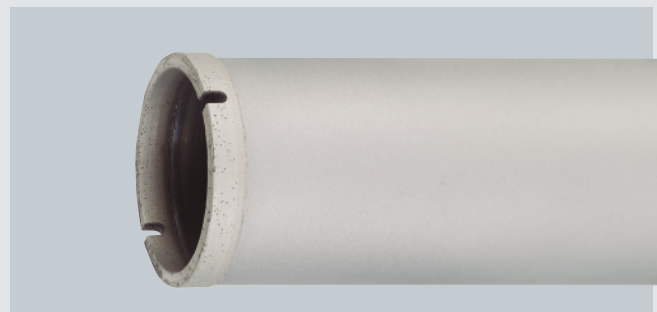
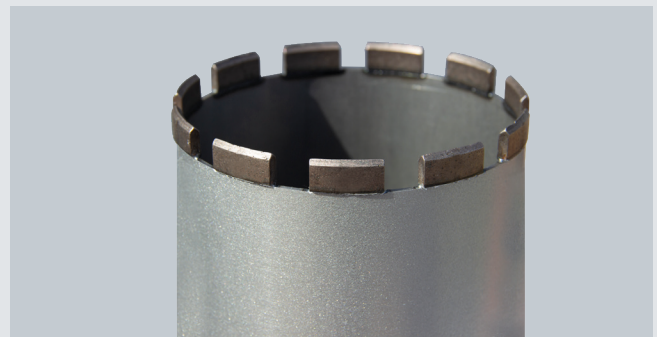

**SOLGA**  
DIAMANT

# WET DRILLING

## SEGMENT SHAPES



### SEGMENTED SHAPE TURBO LASER

- Higher cutting speed due to the lower friction with material to be cut
- Higher performance. Height 12 mm
- Lower vibration and easy cut
- Roof segment with "easy start" function and self-centering
- Jam resistant

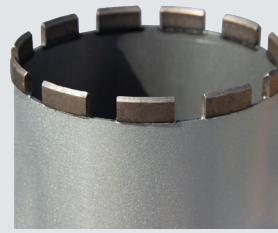

### SEGMENTED SHAPE ROOF

- Straight segment
- Available in height 10 mm
- Roof segment with "easy start" function and self-centering
- Thin segments available for manual drilling



### CONTINUOUS RING

- Suitable for small diameters
- Reduce the blocking of the bit by steel bars
- Longer tool life
- Easy to center and guide the drill

## BONDS

We offer different bonds according to the work requirements:

- **HARD CONCRETE**
  - Designed for calcareous concretes
  - Easy drilling, minimizing vibrations
  - Low aggressiveness and smooth cut when drilling concrete with iron
  - Available with **TURBO LASER & LASER segments**
- **MEDIUM CONCRETE**
  - Designed for concretes with some abrasion
  - Higher duration than ● higher speed than ●
  - Excellent life / speed ratio
  - Available with **TURBO LASER & LASER segments**
- **ABRASIVE CONCRETE**
  - Designed for materials with abrasion
  - High performance segment
  - Recommended for very high power electrical and hydraulic machines
  - Available with **LASER segment**

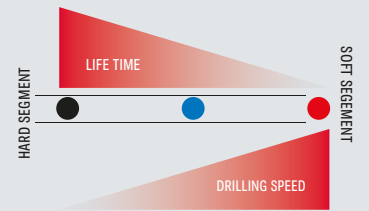

Segment Bond selection according to the drilling performance

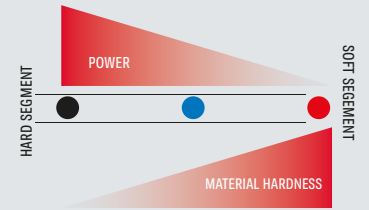

Bond selection according to drilling requirements

## SPEED ADJUSTMENT TABLE

Each drill diameter requires different r.p.m depending on the characteristics of the material to be drilled.  
Concrete with hard aggregate and/or high rebar, low speeds.  
Concrete with soft aggregate and/or low rebar, high speeds.  
The power of the machine influences the speed to be selected.

### HOW TO USE:

1. Select the diameter of the drill bit to be used.
2. Draw a horizontal line until it crosses with the right cutting speed according to the material to be cut.
3. From the intersection draw a vertical line to know the correct revolutions.
4. Select the speed of your machine accordingly.

Using powerful motors at low RPM with small diameter drills shortens the life of the tool dramatically.  
Using low power motors at high RPM makes the segment "harder" and can cause the core bit to stop drilling.

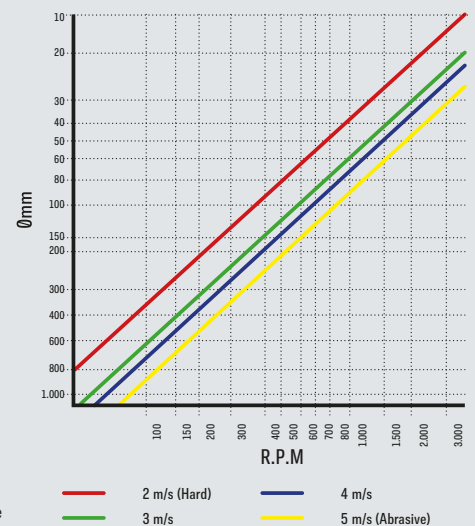



# DRY DRILLING

## DRILL BITS FOR HARD MATERIALS (PORCELAINS)



Vacuum brazed drill bit.  
 High speed and long life for hard materials like porcelains

- Dry drilling possible
- Perform slight oscillation when drilling.
- Never work with percussion
- Available in cylindrical connection of Ø12 mm and in M14 connection up to Ø75 mm

## CONCRETE AND MASONRY DRILL BITS



Laser welded drill bits.  
 M16 connection, adapters for all types available

- Premium quality available from Ø 32 to Ø 202 in length 50 and 150
- Standard quality available in Ø 68 and Ø82 in length 60 mm
- Never work with rock drilling

# SPECIAL APPLICATIONS

## SPECIAL KITCHEN TOP SINK DRILLS

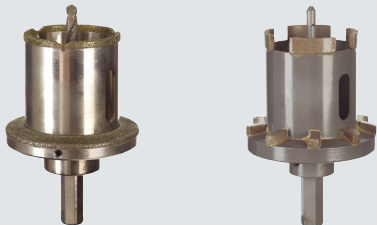

MARBLE ELECTROPLATED

GRANITE SEGMENTED

## PIN DRILL BIT



GRANITE PIN DRILL BIT

## CORE BREAKER



MARBLE ELECTROPLATED

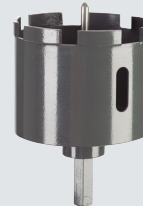

GRANITE SEGMENTED



GRANITE RING BIT

Ask your sales agent to find the right drill bit for your need.

# ACCESORIES

## ADAPTORS AND EXTENDERS



Wide variety of drilling accessories.

## DRILLING KIT

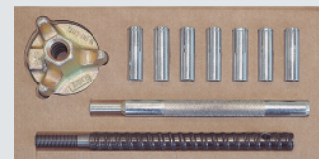

Use the QR code to directly access the digital format of all SOLGA diamant catalogs and see our products in detail.



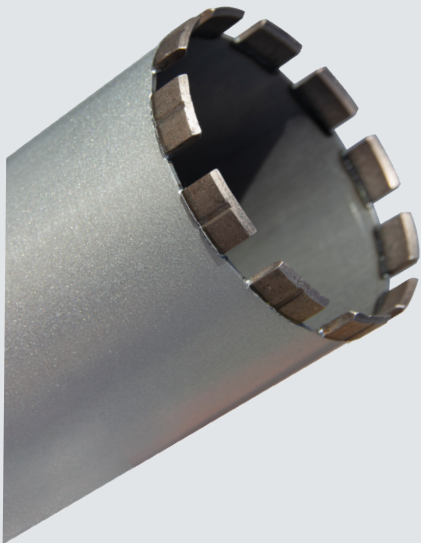

## EUROPEAN DIAMOND TOOL MANUFACTURER

At Solga Diamant, our target is to offer the highest quality and the best service.

We select our suppliers of raw materials with the same standards that we use in our manufacture, guaranteeing the highest level of quality.

In our production process, we use the latest technologies in sintering and welding, obtaining products of the highest quality at competitive prices.

Our commercial network identifies the needs of the markets and together with the factory we develop new core drills to provide the best solution for every requirement.

All our core drills are laser welded. Brazing is also available.

### OUR CONNECTIONS:



### LENGTH AVAILABLE:

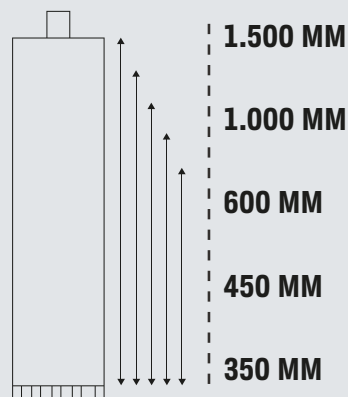

### DIAMETERS AVAILABLE:

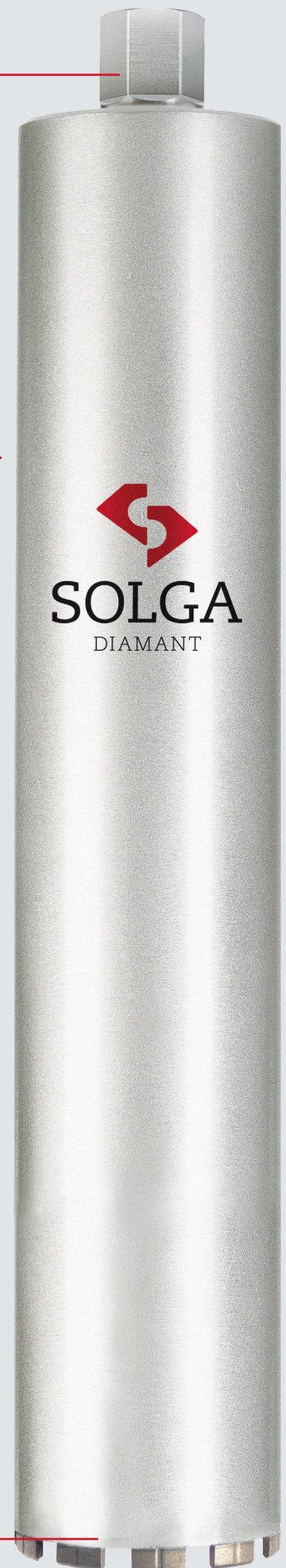
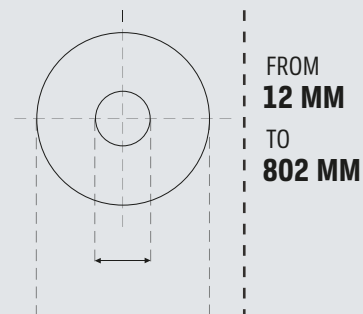

OUR OWN SEGMENT PRODUCTION

# TOOLS



1. CORE DRILLS



5. DIAMOND BLADES FOR NATURAL AND ARTIFICIAL STONES



10. SURFACE PREPARATION



2. FLOOR SAW BLADES



6. DIAMOND WIRE FOR NATURAL STONE



11. DRY CUTTING BLADES



3. WALL SAW AND PRECAST DIAMOND BLADES



7. POLISHING TOOLS FOR NATURAL STONE



12. TABLE SAW BLADES (WET CUTTING)



4. DIAMOND WIRE FOR CONSTRUCTION



8. ROUGHING CUTTERS FOR MARBLE AND GRANITE



13. GRINDING RINGS FOR CALIBRATING



9. GANG SAW FOR MARBLE AND SANDSTONE

**AUTHORIZED SELLING POINT**



**FACTORY / ADMINISTRATION**  
Solga Diamant, S.L.  
Avda. del Compositor Bizet, 49  
08191 Rubí - Barcelona - Spain  
Tel: +34 (93) - 588 46 26

[www.solgadiamant.com](http://www.solgadiamant.com)

**FACTORY / MAIN WAREHOUSE /  
COMMERCIAL DEPARTMENT**  
Solga, S.L.  
Avda. del Compositor Bach, 48 08191  
Rubí - Barcelona - Spain  
Tel: +34 (93) - 588 44 00  
Fax: +34 (93) - 697 24 42  
[info@solgadiamant.com](mailto:info@solgadiamant.com)

**MEXICO, WAREHOUSE /  
COMERCIAL DEPARTMENT**  
Solgamex, S. de R.L. de C.V.  
Tel: +52 (55) 3420-1611  
[mexico@solgadiamant.com](mailto:mexico@solgadiamant.com)

